

# s23 Fixing Instructions

## Foundations

Foundations must be to engineers specification. Omos recommends a minimum cube size of 400mm.

### Type 1 root fixed

note: as an alternative to setting the bollard directly into the foundation, a plastic pipe may be set in the foundation allowing the bollard to be fixed at a later date.

- 1 Set out the position of the bollard/s.
- 2 Where the area has been paved remove sufficient paviors to facilitate excavation.
- 3 Excavate holes to engineer's specification.
- 4 Position bollard precisely ensuring correct position, height and plumb. Prop securely in position.
- 5 Back fill holes with concrete (35N20) leaving sufficient depth for paving slabs and bedding.
- 6 Once set remove props.
- 7 Where necessary cut or core drill the paving slabs and reinstate.
- 8 Render neatly around bollard with non shrink grout, removing any grout residue.

### Type 2 below surface flange

- 1 Cast foundation to engineers specification where bollard is to be located. The surface of the foundation must be level and finish 100mm +10mm, -0mm. Leave to fully cure.
- 2 Position the bollard in the desired location and mark hole positions.
- 3 Drill 12mm holes to a depth of 150mm (or more depending on thickness of paver), insert M12 through bolts (such as Hilti HSA M12).
- 4 Use shims if necessary to ensure the correct height and plumb. Tighten bollard in position.
- 7 Where necessary cut or core drill the paving slabs and reinstate.
- 8 Render neatly around bollard with non shrink grout, removing any grout residue.

### Type 3 above surface flange

- 1 Ensure that the surface which the bollard is to be fixed to is of sufficient size and strength for this purpose.
- 2 Position the bollard in the desired location and mark hole positions.
- 3 Drill following fixing manufacturer's instructions to suit the chosen fixing. Choose a fixing which will accept an M12 SS CSK bolt, either a mechanical anchor (such as Hilti HSC-IR M12\*60) or an internally threaded fixing designed for chemical fixing (such as Hilti HIS-RN M12xL [length to suit]). IMPORTANT, the depth of the hole must be sufficient to allow the fixing to be fully embedded in the concrete rather than partially in the paver and partially in the concrete.
- 4 Insert the fixings into the ground following fixing manufacturer's instructions. Reposition the bollard and screw in M12 SS CSK (stainless steel with countersunk head) into the 4 no. fixings. Where chemical fixing is used (such as Hilti HIT-HY 150) leave sufficient time to cure. Tighten the bolts.

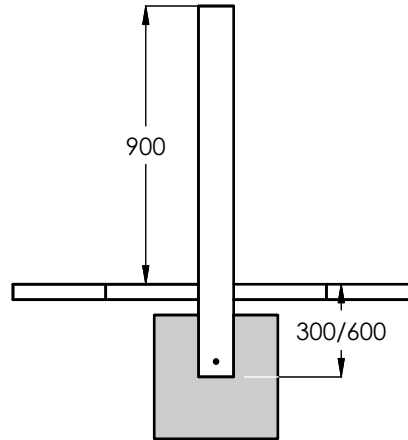

Type 1 root fixed

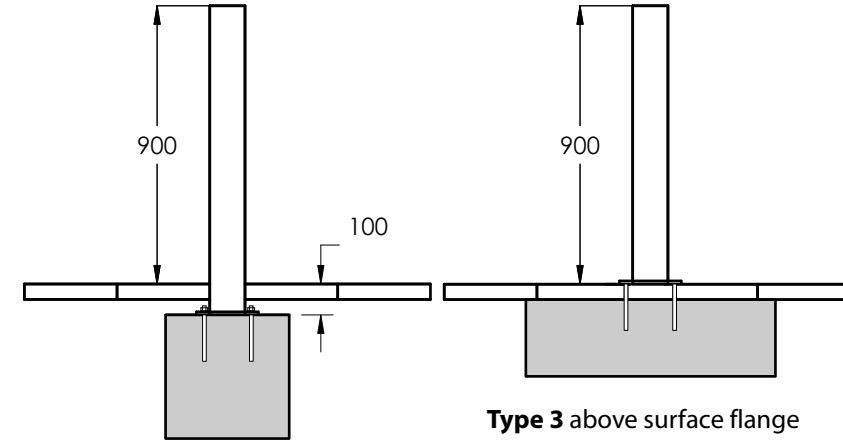

Type 2 below surface flange

Type 3 above surface flange